

LINEA 6A CAMERA HOUSING

Wall Mount Camera Housing,

Weatherproof IP66

Heater with thermostat, Blower kit,

Wall bracket BW6H6

Aluminium body



USER FRIENDLY

All opening and closing operations can be done with just one tool.

FULL OPTIONAL

Power supply, heater and blower kit can be factory installed.

WALL MOUNT

Wall bracket BW6H6 included.

SUITABLE FOR OUTDOOR AND INDOOR

Weatherproof rated, the integrated sunshield and the large window guarantee clear images and no vignetting



tekno system[®]
Italian design for CCTV since 1979









Tekno System S.p.A.
Via Rostoncello, 1 - 36010 Carrè – Italy
Phone: +39 0445 314324 | Fax: +39 0445 314319
Email: info@teknoystem.eu | Web: www.teknoystem.eu

rev. 070912

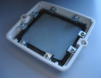

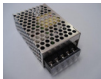

Page 1 / 4

LINEA 6A CAMERA HOUSING

ACCESSORIES

HT	Heater with thermostat: 12-24Vac/dc or 100-240Vac	
V6	Blower kit with thermostat	
VA6	Vandal proof glass (IK08)	
SS6	Sunshield	
AL12, AL24	Power Supply Unit: 400mA, 230Vac/12Vdc or 230Vac/24Vac	
ALWR	Wide Range Power Supply: Vin 88-264V Vout 12Vdc 2,1A	
EL	Camera spacers	
TS	Tamper Switch (available only factory installed)	
BW6H6	Wall bracket	
VG6	Germanium window for thermal cameras (available only factory installed)	

RELATED PRODUCTS

PA1	Pole mount adapter for one bracket	
PA2	Pole mount adapter for two brackets	
CM	Corner mount adapter	
HYP1	Infrared Illuminator	



LINEA 6A CAMERA HOUSING

DIMENSIONS LINEA 6A/250

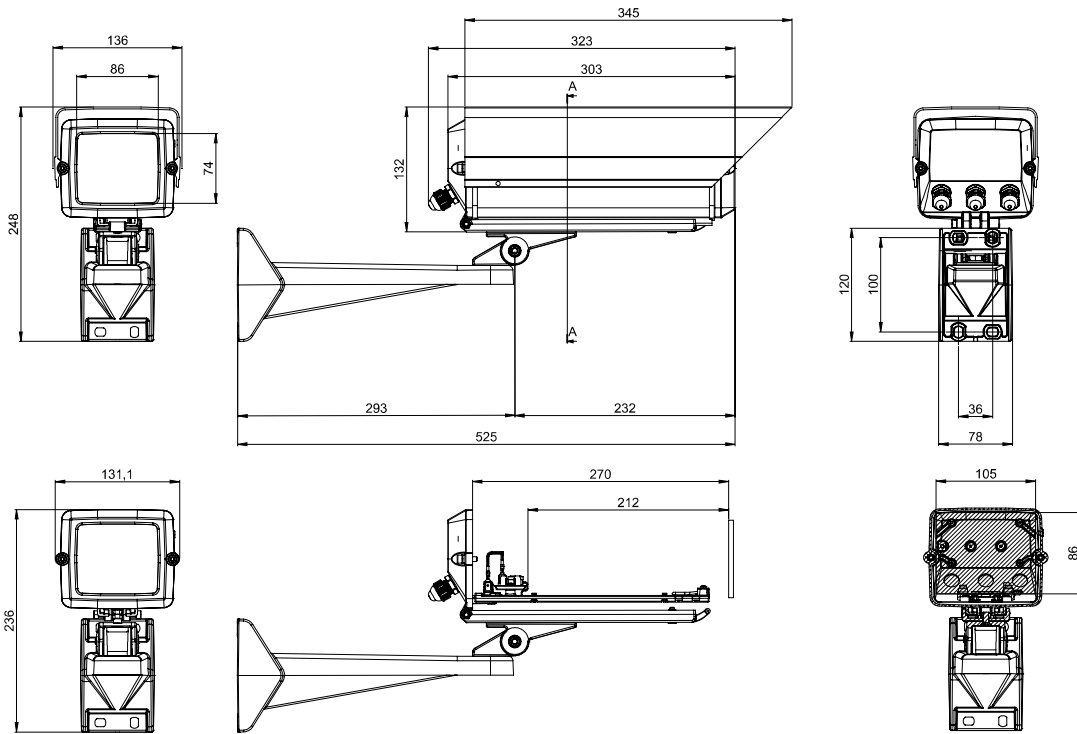

LINEA 6A/300

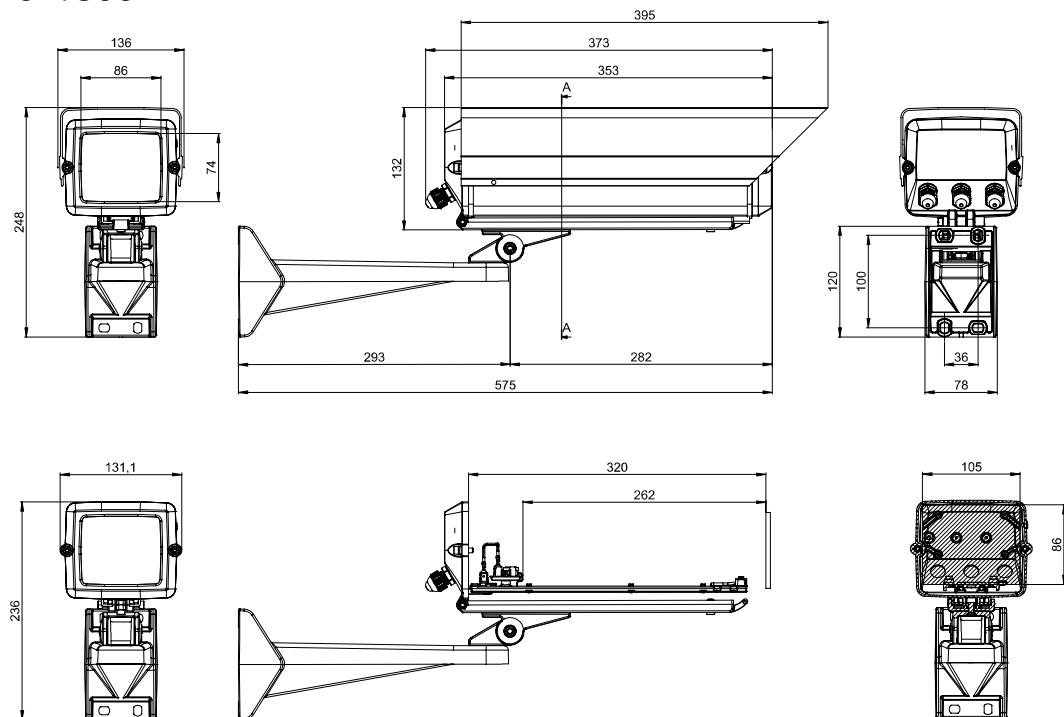

tekno system[®]
Italian design for CCTV since 1979

Tekno System S.p.A.
Via Rostoncello, 1 - 36010 Carrè - Italy
Phone: +39 0445 314324 | Fax: +39 0445 314319
Email: info@tekno-system.eu | Web: www.tekno-system.eu

rev. 070912

Page 3 / 4

LINEA 6A CAMERA HOUSING

LINEA 6A/350

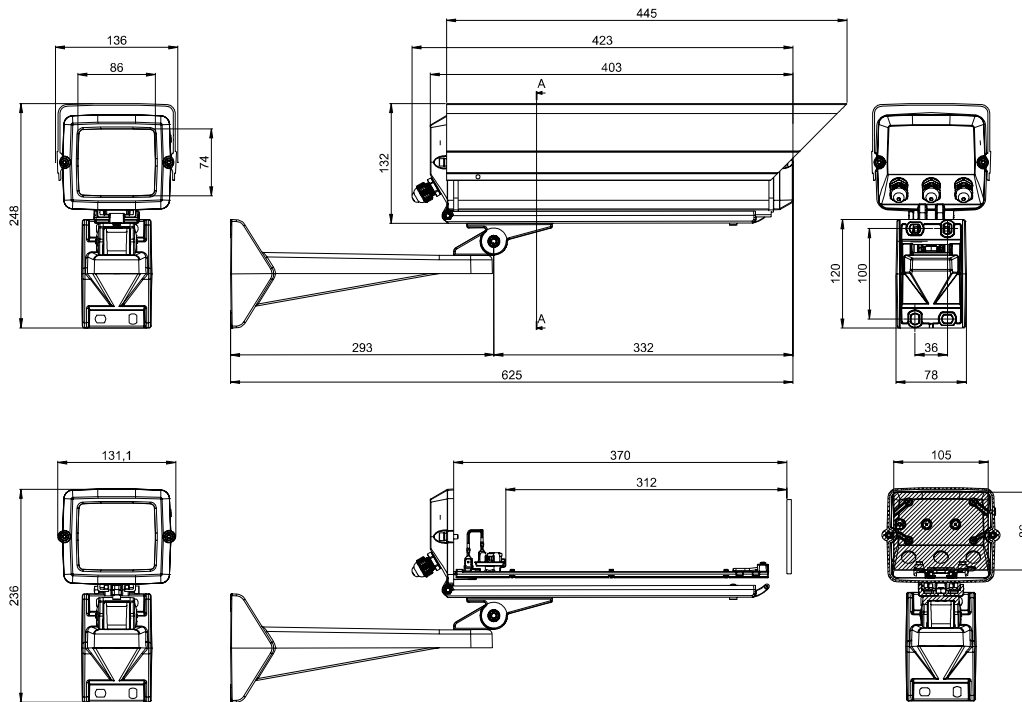

SPECIFICATION

General

- Extruded aluminium body and sunshield
- Die cast Aluminium parts
- RAL9002 Polyester powder coating
- Supplied with: instruction manual, silicagel bag, 1/4" camera fixing screw, BW6H6 wall bracket and swivel head.

Mechanical

- Internal useful area: 105 x 86mm
- Internal useful length LINEA 6A/250: 212mm
- Internal useful length LINEA 6A/300: 262mm
- Internal useful length LINEA 6A/350: 212mm
- Usable Glass Windows 82x 72mm
- Zinc coated screws
- No. 3 M16x1,5 cable glands
(No. 2 cable glands with blower kit)

Electrical

- Heater Thermostat $T_{on} 15^{\circ}\text{C} (59^{\circ}\text{F}) \pm 5^{\circ}\text{C}$ $T_{off} 22^{\circ}\text{C} (71.6^{\circ}\text{F}) \pm 4^{\circ}\text{C}$
- Heater PTC:
 - 100-240VAC input (average consumption 10W, 40W peak)
 - 12-24VAC/DC input (average consumption 7W, 20W peak)
- Blower Thermostat $T_{on} 37^{\circ}\text{C} (98.6^{\circ}\text{F}) \pm 4^{\circ}\text{C}$ $T_{off} 27^{\circ}\text{C} (80.6^{\circ}\text{F}) \pm 3^{\circ}\text{C}$
- Blower with double air filter:
 - 230VAC input / 24VDC fan output (consumption 1W)
 - 24VAC input / 24VDC fan output (consumption 1W)
 - 12VDC input / 12VDC fan output (consumption 1W)
- Camera power supply unit:
ALWR: Vin 88-264V~ 47/63Hz Vout 12VDC 2,1A;
AL12 Vin 230V~ 50Hz Vout 12VDC 400mA;
AL24 Vin 230V~ 50Hz Vout 24V~ 50Hz 400mA;

Environment

- Indoor / Outdoor applications
- Temperature range with heater:
-20 °C (-4 °F) up to +50 °C (+122 °F)
- IP66 weatherproof rating (according to EN60529)
IP54 in case of blower kit with air filters installed
- CE according to EN61000-6-3, EN60950, EN50130-4
- RoHS compliant

Technical data and product features might be modified without any warning.



tekno system®

Italian design for CCTV since 1979

Tekno System S.p.A.

Via Rostoncello, 1 - 36010 Carrè - Italy

Phone: +39 0445 314324 | Fax: +39 0445 314319

Email: info@teknoystem.eu | Web: www.teknoystem.eu

rev. 070912

Page 4 / 4