

1. Intended use:

The RACK 19" cabinet enables integrating CCTV, AC, I&HAS, RTV, LAN, or other systems in medium and big companies. It is intended for devices manufactured in enclosures of the 19" standard. Due to the RACK cabinets, the devices are aesthetically mounted and protected against mechanical damage

2. Specifications:

SPECIFICATIONS	
Mounting dimensions:	W=19", H=42U
External dimensions:	W=600, H=2055, D=800 [mm, +/-2]
Net/gross weight:	104,5 / 112,1 [kg]
Materials:	<ul style="list-style-type: none"> - RACK mounting rails: cold-rolled steel SPCC 2mm RAL 9004 - bolted - horizontal mounting rails: cold-rolled steel SPCC 1,5mm RAL 9004 - bolted - frame: cold-rolled steel SPCC 1,2mm RAL 9004 - welded - front door: 5mm toughened glass / SPCC 1,2mm RAL 9004 - hinged - side panel :cold-rolled steel SPCC 1,2mm RAL 9004 - removable - rear door: cold-rolled steel SPCC 1,2mm RAL 9004 - hinged
Static load:	800 kg (with leveling feet)
Use:	inside, IP20
Notes:	<ul style="list-style-type: none"> - adjustable distance between front and rear RACK rails - ventilation holes in the front door, top and bottom panel - possible mounting of a fan tray in the top panel – RAWP (max. 2 pieces.) - cable ducts in the top and bottom panel - 4 casters without locks and 4 leveling feet included - possible assembly of a 100mm high plinth - RAC168 - lockable front door (2 keys in set) - lockable rear door (2 keys in set) - side panel - lock assembly possible - RAZB16 - ready-to-assemble
Certificates, declarations:	RoHS

3. Structure of the RACK cabinet.

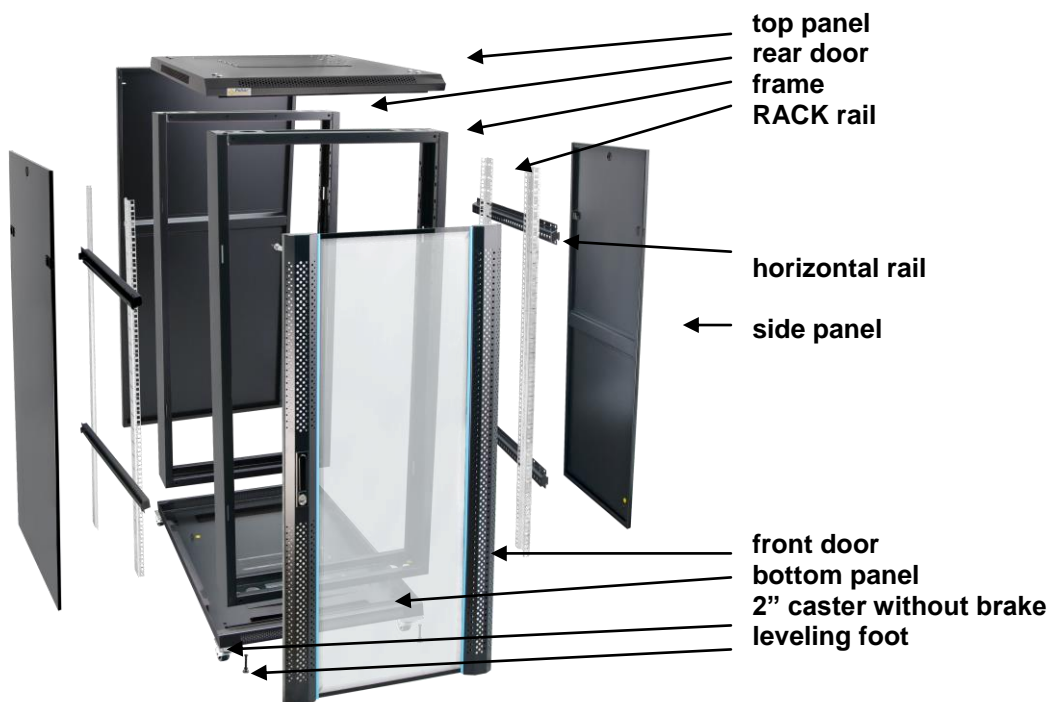

4. Assembling instructions:

The free standing, ready-to-assemble RACK cabinet is delivered in 5 separate packages.

4.1) Lay two **frames** of the RACK cabinet (package 2/5 and 3/5)



Fig.1

4.2) Attach the **bottom panel** to the cabinet's **frames** from the left, and the **top panel** from the right (package 1/5).

Bolt with screws with nuts (16pcs - package 1/5). Bolt the **casters** and the **leveling feet** into the **bottom panel** of the cabinet (package 1/5).



Fig.2

4.3) Stand the RACK cabinet.



Fig.3

4.4) From the inside of the cabinet's **frames** (at front and back), mount two **cage nuts** on $\frac{1}{4}$ and $\frac{3}{4}$ of cabinet's height, accordingly to the figure below.



Fig.4

4.5) In **horizontal rails** (package 1/5), mount two **cage nuts** at front and back, as shown in Fig.4.

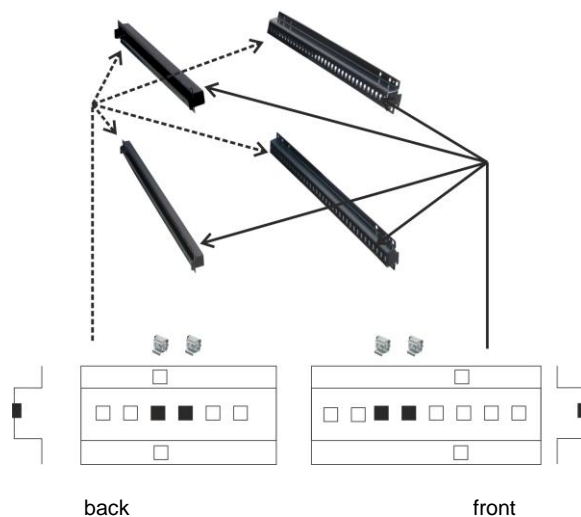

Fig.5

4.6) Mount the **horizontal rails** from the inside, as shown in Fig.6.

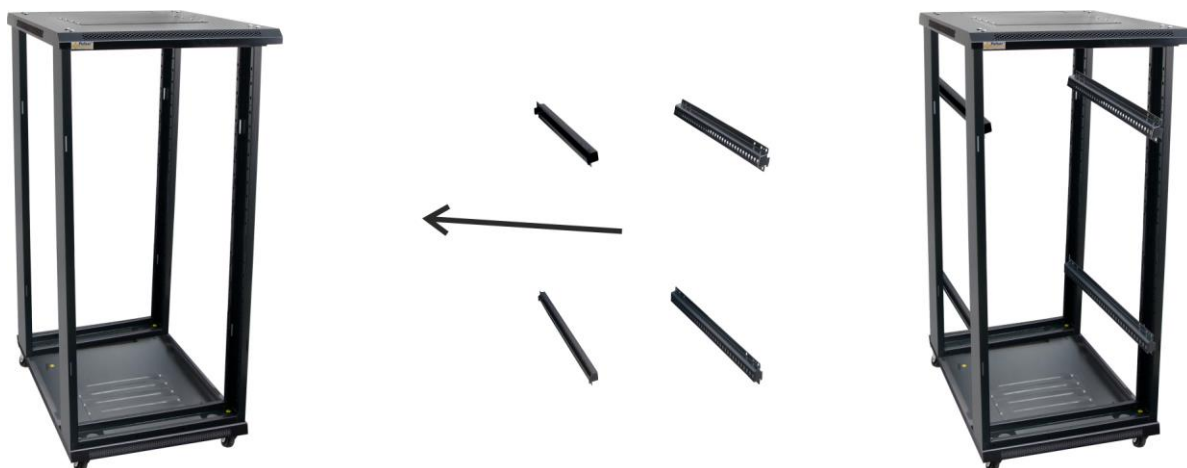

Fig.6

4.7) Mount the **RACK rails** from the inside, as in Fig.7.

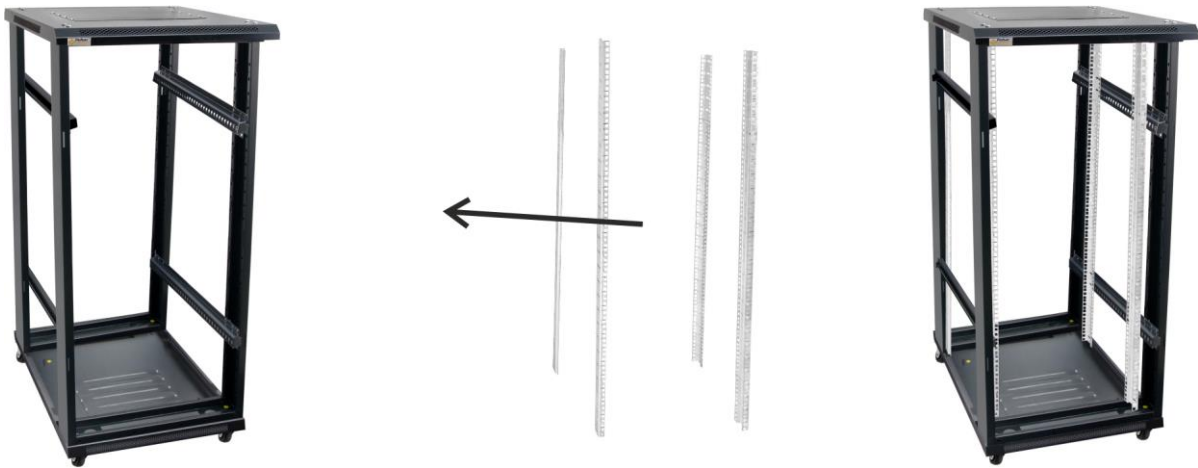
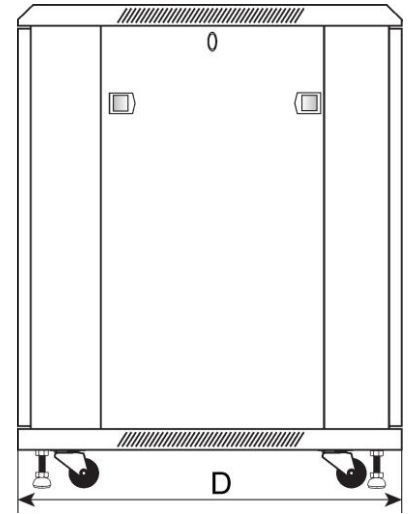
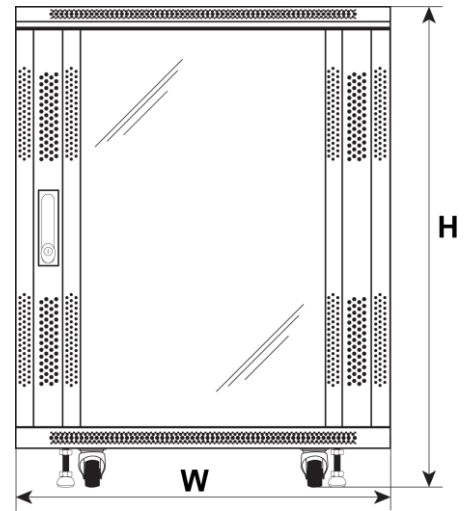

Fig.7

4.8) Mount the **side panels, front and rear doors** - Fig.8.



Fig.8



MANUFACTURER

Pulsar

Siedlec 150,

32-744 Łapczyca

Tel. 14-610-19-40, Fax. 14-610-19-50

e-mail: biuro@pulsar.pl, sales@pulsar.pl

http:// www.pulsar.pl, www.zasilacze.pl

WARRANTY

12 months from the date of purchase.

THE WARRANTY IS VALID only upon presentation of the item's proof of purchase.